

# Dual-channel Dome Wall Mounting Assembling Bracket

TR-JB07/WM03-H-IN



## Specifications

Bracket	Description
Application	Wall Mounting Assembling Bracket for IPC322XSS Series Dual-channel Dome
Dimensions(bracket)	Φ 229.3mm x 126.7mm x 126.4mm (9.0" x 5.0" x 5.0" )
Weight(bracket)	1.02kg (2.25lb)
Material(bracket)	Aluminum alloy

## Dimensions

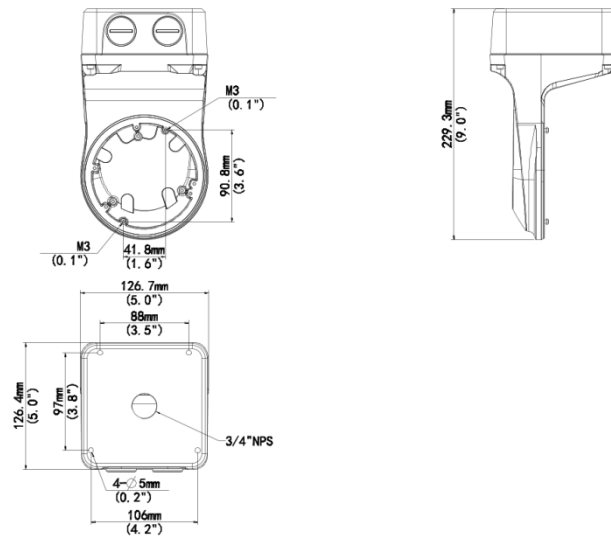

### Zhejiang Uniview Technologies Co., Ltd.

No. 369, Xietong Road, Xixing Sub-district, Binjiang District, Hangzhou City, 310051, Zhejiang Province, China

Email: [overseasbusiness@uniview.com](mailto:overseasbusiness@uniview.com); [globalsupport@uniview.com](mailto:globalsupport@uniview.com)

<http://www.uniview.com>

©2024 Zhejiang Uniview Technologies Co., Ltd. All rights reserved.

\*Product specifications and availability are subject to change without notice.

\*Despite our best efforts, technical or typographical errors may exist in this document. Uniview cannot be held responsible for any such errors and reserves the right to change the contents of this document without prior notice.